

### Parts List For 19 Inch Band Saw Model No. SBW-4800 A

KEY NO.	PARTS NO.	DESCRIPTION	SIZE	Q'TY
1				
2				
3				
4	995101	RING	M10	1
5	136101	MACHINE BODY		1
6	SS050100	SET BOLT	M5x5	1
7	135067	BUSHING		1
8	WF061310	FLAT WASHER	M6x $\phi$ 13	2
9	IC135005	POWER CORD		1
10	NH061000	NUT	M6	1
11	135040	POINTER		1
12	135073	STEP SCREW		1
13	135012	UPPER SHAFT		1
14	PS053500	SPRING PIN	$\phi$ 5x35	1
15	135017	UPPER WHEEL SHAFT HINGE		1
16	135066	UPPER WHEEL SHAFT		1
17	135039	BUSHING		3
18	BB620403	BALL BEARING	6204LLU	4
19	136002	UPPER WHEEL	$\phi$ 19"	1
20	RR470000	RETAINING RING	R47	4
21	WF083030	FLAT WASHER	M8x $\phi$ 30	2
22	SR089400	HEX SOCKET BOLT	M8X16	2
23	136010	SAW BLADE	143"x3/4"X0.5mm	1
24	WS080000	SPRING WASHER	M8	2
25	SR060600	HEX SOCKET BOLT	M6x30	6
26	135048	TIRE		2
27	136003	LOWER WHEEL	$\phi$ 19"	1
28	135007	IDLE PULLEY		1
29	NH633801	NUT	1"-14 UNF	1
30	WS630000	SPRING WASHER	1"	1

KEY NO.	PARTS NO.	DESCRIPTION	SIZE	Q'TY
31	IM135002	MOTOR CORD		1
32	135032	SPRING		1
33	PS031600	PIN	φ 3X16	1
34	135042	LOCATE BLOCK		1
35	994301	BEARING	51201	1
36	994542	SWITCH		1
37	135002	HANDLE WHEEL		1
38	136007	ADJUSTING BOLT		1
39	SF050200	PAN HEAD BOLT W/FLANGE	M5X10	8
40	WE050000	STAR WASHER	M5	4
41	SF059400	PAN HEAD BOLT W/FLANG	M5X16	2
42	NH050800	NUT	M5	4
43	135027	SWITCH PLATE		1
44	SR089400	HEX SOCKET BOLT	M8x16	2
45	WF083030	FLAT WASHER	M8x φ 30	2
46	135016	UPPER WHEEL SLIDING BRACKET		1
47	SR061000	HEX SOCKET BOLT	M6x50	1
48	BR000041	RIVET	φ 3.2x6	8
49	SR060200	HEX SOCKET BOLT	M6x10	1
50	135004	LIMPID PIECE		2
51				
52				
53				
54				
55	136008	UPPER WHEEL COVER		1
56	SHO60500	HEX HEAD BOLT	M6x25	2
57	WF061310	FLAT WASHER	M6x φ 13	2
58	135051	BRUSH		2
59	SR060500	HEX SOCKET BOLT	M6x25	1
60	135041	KNOB		2

KEY NO.	PARTS NO.	DESCRIPTION	SIZE	Q'TY
61	NL061000	NYLON NUT	M6	4
62	709416	STRAIN RELIEF	M16	2
63	135011	HEIGHT POINTER		1
64	NH081300	NUT	M8	1
65	SH081800	HEX HEAD LOLT	M8x90	1
66	135022	KNOB SCREW		1
67	135020	KNOB SCREW		1
68	135028	LOCATE HANDLE	M10	1
69	135030	CAM		1
70	135038	LOCATE BLOCK		1
71	620021	KNOB		1
72	620020	LEVER ROD		1
73	NH121900	NUT	M12	1
74	135036	SHAFT		1
75	SJ080400	HEX SOCKET BOTTOM HEAD SCREW	M8x20	4
76	WS080000	SPRING WASHER	M8	4
77	WS060000	SPRING WASHER	M6	2
78	135013	COVER		1
79	SS080400	SET SCREW	M8x20	4
80	NH081300	NUT	M8	4
81	135005	LOWER WHEEL SHAFT		1
82	MH135004	MOTOR	1.5 HP	1
83	SR100500	HEX HEAD BOLT	M10x25	2
84	WS100000	SPRING WASHER	M10	2
85	135064	MOTOR BRACKET		1
86	SJ080400	HEX SOCKET BOTTOM HEAD HEAD SCREW	M8x20	4
87	135056	PLATE		1
88	SF050200	PAN HEAD BOLT W/FLANGE	M5x10	2
89	135065	LOCATE BLOCK		1
90	KS050535	KEY	5x5x35	1

KEY NO.	PARTS NO.	DESCRIPTION	SIZE	Q'TY
91	SH080402	HEX HEAD BOLT	M8x20(L.H)	1
92	135008	MOTOR PULLEY		1
93	LA420000	V-BELT	A42	1
94	SR060200	HEX SOCKET BOLT	M6x10	1
95	136006	LOWER WHEEL COVER		1
96	WF061310	FLAT WASHER	M6x13	2
97	WF083030	FLAT WASHER	M8x30	1
98	SR100700	HEX SOCKET BOLT	M10x35	2
99	NH101700	NUT	M10	1
100	135061	SMALL GEAR		2
101	135063	KNOB SCREW		1
102	135021	TRUNNION SUPPORT BRACKET		1
103	WS100000	SPRING WASHER	M10	3
104	WF102325	FLAT WASHER	M10x $\varphi$ 23	2
105	SR069400	HEX SOCKET BOLT	M6x16	1
106	SR060900	HEX SOCKET BOLT	M6x45	1
107	135045	ADJUST BLOCK		1
108	NH061000	NUT	M6	2
109	135009	ADJUST BOLT	M6	1
110	BB600002	BALL BEARING	6000ZZ	1
111	SJ100400	HEX SOCKET BOTTOM HEAD SCREW	M10x20	1
112	WF081820	FLAT WASHER	M8x $\varphi$ 18	4
113	WF081820	FLAT WASHER	M8x $\varphi$ 18	2
114	SP049100	PAN HEAD BOLT	M4x6	4
115	135052	GEAR PLATE		2
116	NL081300	NYLOW NUT	M8	2
117	SP049100	PAN HEAD BOLT	M4x6	1
118	135044	HANDLE		1
119	WF040808	FLAT WASHER	M4x $\varphi$ 8	2
120	135078	POINTER		1

KEY NO.	PARTS NO.	DESCRIPTION	SIZE	Q'TY
121	135025	TRUNNION PLATE		2
122	WS080000	SPRING WASHER	M8	4
123	SH089400	HEX HEAD BOLT	M8x16	4
124	SC081600	CARRIAGE BOLT	M8x80	1
125	AB198003	18" FENCE SET		1
	198002	ADJUST BASE		1
	198003	FIXED SHAFT		2
	198004	FIXED LUMP		1
	198005	SHAFT		1
	198006	SPRING PIECE		1
	198007	CONVEX		1
	198008	BRACKET		1
	198010	SPACE BUSHING		2
	198012	ADJUST SCREW		1
	198013	HANDLE		1
	198014	GUARD PIECE		2
	198015	GUARD PIECE		2
	135016	PLUG		2
	198022	FIXED BASE	L-710	1
	198023	SQUARE TUBE	L=710	1
	198024	SUPPORT TUBE	L=640	1
	LM000539	SCALE		1
	SF040200	PAN HEAD BOLT W/FLANGE	M4x10	1
	SH060400	HEX HEAD BOLT	M6x20	2
	SR069400	HEX SOCKET BOLT	M6x16	2
	NH061000	NUT	M6	2
	ST039200	TAPPING SCREW	3.5x8	4
	SF049100	PAN HEAD BOLT W/FLANGE	M4x6	2
	NH081300	NUT	M8	1
	SR061100	HEX SOCKET BOLT	M6x55	4

KEY NO.	PARTS NO.	DESCRIPTION	SIZE	Q'TY
	WS060000	SPRING WASHER	M6	2
126	136004	TABLE	19"x19"	1
127	135010	TABLE INSERT		1
128	100038	TABLE PIN		1
129	SR069100	HEX SOCKET BOLT	M6x6	2
130	135031	LEFT COVER		1
131	150013	THUMB SCREW	M6x16	2
132	135059	LOWER BLADE GUIDE SUPPORT		1
133	135058	GUIDE RING		2
134	135018	LOWER ADJUST SHAFT		4
135	135035	RIGHT COVER		1
136	SR050200	HEX SOCKET BOLT	M5x10	2
137	WF051210	FLAT WASHER	M5x $\varnothing$ 12	2
138	135034	PROTECT COVER (ASM)		1
139				
140	135073	STEP SCREW		1
141	135054	FLAT WASHER		1
142	135037	SLIDING PLATE		1
143	RS150000	RETAINING RING	S15	1
144	BB620202	BALL BEARING	6202ZZ	1
145	135055	UPPER BLADE GUIDE SUPPORT		1
146	135058	GUIDE RING		2
147	150013	THUMB SCREW	M6x16	2
148	SC081700	CARRIAGE BOLT	M8x85	1
149	SR069400	HEX SOCKET BOLT	M6x16	3
150	135053	ADJUST BAR		1
151	135060	UPPER SPACING SLEEVE		1
152	SR060400	HEX SOCKET BOLT	M6x20	2
153	135057	UPPER GUIDE SUPPORT BLOCK		1
154	SP040200	PAN HEAD BOLT	M4x10	1

KEY NO.	PARTS NO.	DESCRIPTION	SIZE	Q'TY
155	NH040700	NUT	M4	1
156	135029	RACK		1
157	135047	UPPER GUIDE TUBE		1
158	135006	HANDLE WHEEL		1
159	SR060400	HEX SOCKET BOLT	M6x20	1
160	135015	LOCATE BUSHING		1
161	135043	BUSHING		1
162	SJ080400	HEX SOCKET BOTTOM HEAD SCREW	M8x20	4
163	WS080000	SPRING WASHER	M8	9
164	135050	GUIDE BRACKET		1
165	135033	WORM CYLINDER		1
166	135062	FIXED PLATE		1
167	135049	GEAR		1
168	016320	FIXED BOLT		1
169	135046	COVER		1
170	SR089400	HEX SOCKET BOLT	M8x16	4
171	SN049200	COUNTER SUNK BOLT	M4x8	3
172	SS069400	SET BOLT	M6x16	1
173	AB198101	MITER GAUGE ASS'Y		1
	198101	GUIDE BAR		1
	198102	GUIDE		1
	198103	POINTER		1
	198104	NYLON WASHER		1
	198105	HANDLE	1/4"	1
	198106	MITER GAUGE BODY		1
	198107	SHAFT		1
	SN069200	COUNTER SUNK BOLT	M6x6	1
	SF059200	PAN HEAD BOLT W/FLANGE	M5x8	1
174	135079	BUSHING		1
175	SR060400	HEX SOCKET BOLT	M6X20	1
176	SF050200	PAN HEAD BOLT W/FLANGE	M5X10	2

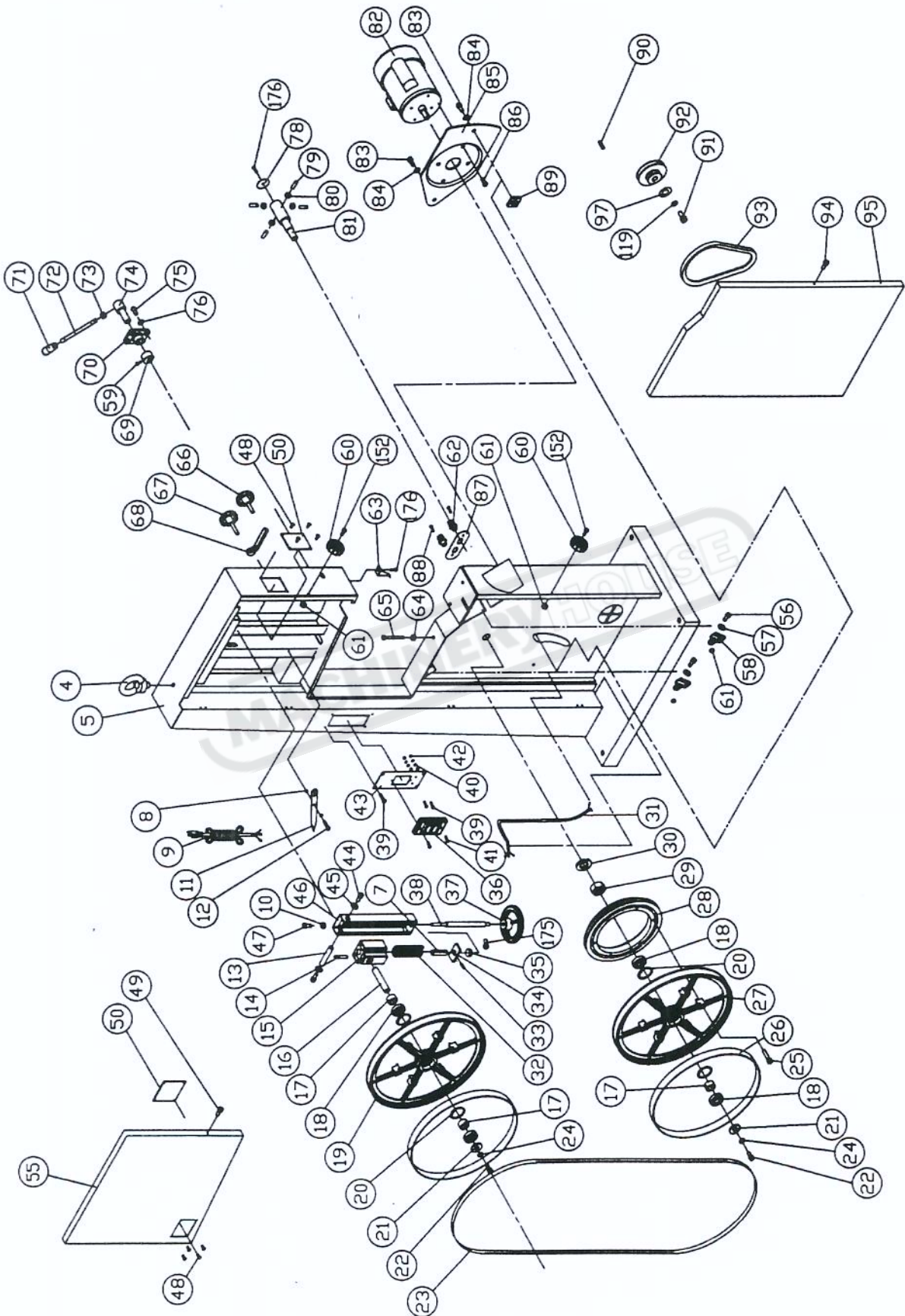



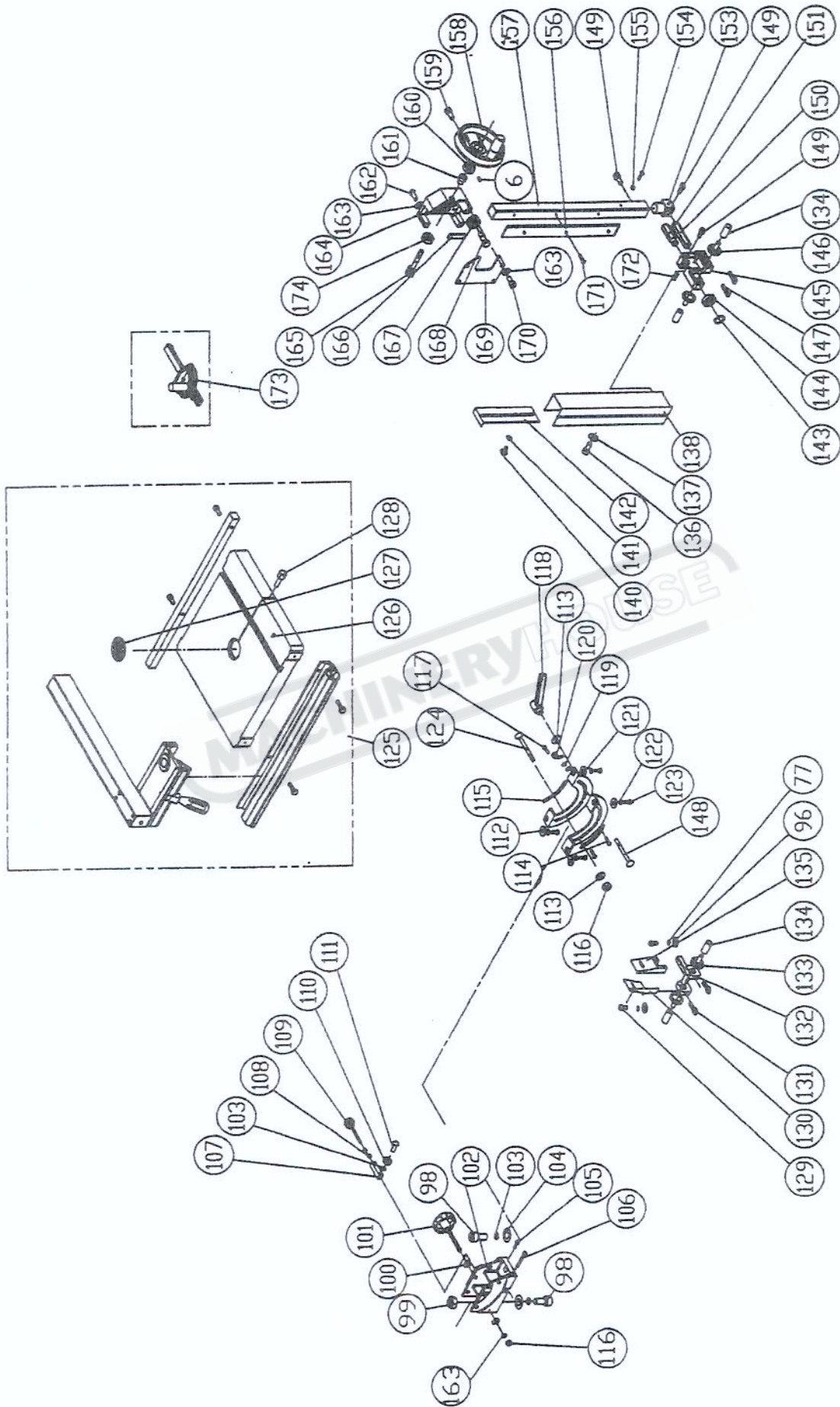

### Parts List For 19 Inch Band Saw Model No SBW-4800 CE

KEY NO.	PARTS NO.	DESCRIPTION	SIZE	Q'TY
1	130040	SWITCH COVER		1
2	NH040700	NUT	M4	2
3	709416	STRAIN RELIEF	M16	1
4	995101	RING	M10	1
5	136001	MACHINE BODY		1
6	SS050100	SET BOLT	M5X5	2
7	IC135002	SWITCH CORD		1
8	WF061310	FLAT WASHER	M6x $\phi$ 13	2
9	IC135001	POWER CORD		1
10	NH061000	NUT	M6	1
11	135040	POINTER		1
12	135073	STEP SCREW		1
13	135012	UPPER SHAFT		1
14	PS053500	SPRING PIN	$\phi$ 5x35	2
15	135017	UPPER WHEEL SHAFT HINGE		1
16	135066	UPPER WHEEL SHAFT		1
17	135039	BUSHING		3
18	BB620403	BALL BEARING	6204LLU	4
19	136002	UPPER WHEEL	$\phi$ 19"	1
20	RR470000	RETAINING RING	R47	4
21	WF083030	FLAT WASHER	M8x $\phi$ 30	2
22	SR089400	HEX SOCKET BOLT	M8X16	2
23	136010	SAW BLADE	143"x3/4"X0.5mm	1
24	WS080000	SPRING WASHER	M8	2
25	SR060600	HEX SOCKET BOLT	M6x30	6
26	135048	TIRE		2
27	136003	LOWER WHEEL	$\phi$ 19"	1
28	135007	IDLE PULLEY		1
29	NH633801	NUT	1"-14 UNF	1
30	WS630000	SPRING WASHER	1"	1

KEY NO.	PARTS NO.	DESCRIPTION	SIZE	Q'TY
31	IM135001	MOTOR CORD		1
32	135032	SPRING		1
33	PS031600	PIN	φ 3X16	1
34	135042	LOCATE BLOCK		1
35	994301	BEARING	51201	1
36	170245	CE SWITCH	JD3	1
37	135002	HANDLE WHEEL		1
38	136007	ADJUSTING BOLT		1
39	SF050200	PAN HEAD BOLT W/FLANGE	M5X10	8
40	WE050000	STAR WASHER	M5	4
41	135067	BUSHING		1
42	NH050800	NUT	M5	4
43	135070	SWITCH PLATE		1
44	SR089400	HEX SOCKET BOLT	M8x16	2
45	WF083030	FLAT WASHER	M8x φ 30	2
46	135016	UPPER WHEEL SLIDING BRACKET		1
47	SR061000	HEX SOCKET BOLT	M5x50	1
48	BR000041	RIVET	φ 3.2x6	8
49	SR060200	HEX SOCKET BOLT	M6x10	1
50	135004	LIMPID PIECE		2
51	SF040600	PAN HEAD BOLT W/FLANGE	M4x30	2
52	136012	DOOR LATCH SWITCH (ASM)		1
53	SF050200	PAN HEAD BOLT W/FLANGE	M5x10	4
54	136009	SWITCH BUSHING		1
55	136005	UPPER WHEEL COVER		1
56	SR060500	HEX SOCKET BOLT	M6x25	2
57	WF061310	FLAT WASHER	M6x φ 13	2
58	135051	BRUSH		2
59	SR060500	HEX SOCKET BOLT	M6x25	1
60	135041	KNOB		2

KEY NO.	PARTS NO.	DESCRIPTION	SIZE	Q'TY
61	NL061000	NYLON NUT	M6	4
62	709416	STRAIN RELIEF	M16	2
63	135011	HEIGHT POINTER		1
64	NH081300	NUT	M8	1
65	SH081800	HEX HEAD LOLT	M8x90	1
66	135022	KNOB SCREW		1
67	135020	KNOB SCREW		1
68	135028	LOCATE HANDLE	M10	1
69	135030	CAM		1
70	135038	LOCATE BLOCK		1
71	620021	LEVER ROD		1
72	620020	KNOB		1
73	NH121900	NUT	M12	1
74	135036	SHAFT		1
75	SJ080400	HEX SOCKET BOTTOM HEAD SCREW	M8x20	4
76	WS080000	SPRING WASHER	M8	4
77	WS060000	SPRING WASHER	M6	2
78	135013	COVER		1
79	SS080400	SET SCREW	M8x20	4
80	NH081300	NUT	M8	4
81	135005	LOWER WHEEL SHAFT		1
82	MH135004	MOTOR	1.5 HP	1
83	SR100500	HEX HEAD BOLT	M10x25	2
84	WS100000	SPRING WASHER	M10	2
85	135064	MOTOR BRACKET		1
86	SJ080400	HEX SOCKET BOTTOM HEAD SCREW	M8x20	4
87	135056	PLATE		1
88	SF050200	PAN HEAD BOLT W/FLANGE	M5x10	2
89	135065	LOCATE BLOCK		1
90	KS050535	KEY	5x5x35	1

KEY NO.	PARTS NO.	DESCRIPTION	SIZE	Q'TY
91	SH080402	HEX HEAD BOLT	M8x20(L.H)	1
92	135008	MOTOR PULLEY		1
93	LA440000	V-BELT	A44	1
94	SR060200	HEX SOCKET BOLT	M6x10	1
95	136006	LOWER WHEEL COVER		1
96	WF061310	FLAT WASHER	M6x13	2
97	WF083030	FLAT WASHER	M8x30	1
98	SR100700	HEX SOCKET BOLT	M10x35	2
99	NH101700	NUT	M10	1
100	135061	SMALL GEAR		2
101	135063	KNOB SCREW		1
102	135021	TRUNNION SUPPORT BRACKET		1
103	WS100000	SPRING WASHER	M10	3
104	WF102325	FLAT WASHER	M10x $\varnothing$ 23	2
105	SR069400	HEX SOCKET BOLT	M6x16	1
106	SR060900	HEX SOCKET BOLT	M6x45	1
107	135045	ADJUST BLOCK		1
108	NH061000	NUT	M6	2
109	135009	ADJUST BOLT	M6	1
110	BB600002	BALL BEARING	6000ZZ	1
111	SJ100400	HEX SOCKET BOTTOM HEAD SCREW	M10x20	1
112	WF081820	FLAT WASHER	M8x $\varnothing$ 18	4
113	WF081820	FLAT WASHER	M8x $\varnothing$ 18	2
114	SP049100	PAN HEAD BOLT	M4x6	4
115	135052	GEAR PLATE		2
116	NL081300	NYLON NUT	M8	2
117	SP049100	PAN HEAD BOLT	M4x6	1
118	135044	HANDLE		1
119	WF040808	FLAT WASHER	M4x $\varnothing$ 8	2
120	135078	POINTER		1

KEY NO.	PARTS NO.	DESCRIPTION	SIZE	Q'TY
121	135025	TRUNNION PLATE		2
122	WS080000	SPRING WASHER	M8	4
123	SH089400	HEX HEAD BOLT	M8x16	4
124	SC081600	CARRIAGE BOLT	M8x80	1
125	AB198003	18" FENCE SET		1
	198002	ADJUST BASE		1
	198003	FIXED SHAFT		2
	198004	FIXED LUMP		1
	198005	SHAFT		1
	198006	SPRING PIECE		1
	198007	CONVEX		1
	198008	BRACKET		1
	198010	SPACE BUSHING		2
	198012	ADJUST SCREW		1
	198013	HANDLE		1
	198014	GUARD PIECE		2
	198015	GUARD PIECE		2
	198016	PLUG		2
	198022	FIXED BASE	L=710	1
	198023	SQUARE TUBE	L=710	1
	198024	SQUARE TUBE	L=640	1
	LM000539	SCALE		1
	SF040200	PAN HEAD BOLT W/FLANGE	M4x10	1
	SH060400	HEX HEAD BOLT	M6x20	2
	SR069400	HEX SOCKET BOLT	M6x16	2
	NH061000	NUT	M6	2
	ST039200	TAPPING SCREW	3.5x8	4
	SF049100	PAN HEAD BOLT W/FLANGE	M4x6	2
	NH081300	NUT	M8	1
	SR061100	HEX SOCKET BOLT	M6x55	4

KEY NO.	PARTS NO.	DESCRIPTION	SIZE	Q'TY
	WS060000	SPRING WASHER	M6	2
126	136004	TABLE	19"x19"	1
127	135010	TABLE INSERT		1
128	100038	TABLE PIN		1
129	SR069100	HEX SOCKET BOLT	M6x6	2
130	135031	LEFT COVER		1
131	150013	THUMB SCREW	M6x16	2
132	135059	LOWER BLADE GUIDE SUPPORT		1
133	135058	GUIDE RING		2
134	135018	LOWER ADJUST SHAFT		4
135	135035	RIGHT COVER		1
136	SR050200	HEX SOCKET BOLT	M5x10	2
137	WF051210	FLAT WASHER	M5x $\phi$ 12	2
138	135034	PROTECT COVER (ASM)		1
139				
140	135073	STEP SCREW		1
141	135054	FLAT WASHER		1
142	135037	SLIDING PLATE		1
143	RS150000	RETAINING RING	S15	1
144	BB620202	BALL BEARING	6202ZZ	1
145	135055	UPPER BLADE GUIDE SUPPORT		1
146	135058	GUIDE RING		2
147	150013	THUMB SCREW	M6x16	2
148	SC081700	CARRIAGE BOLT	M8x85	1
149	SR069400	HEX SOCKET BOLT	M6x16	3
150	135053	ADJUST BAR		1
151	135060	UPPER SPACING SLEEVE		1
152	SR060400	HEX SOCKET BOLT	M6x20	2
153	135057	UPPER GUIDE SUPPORT BLOCK		1
154	SP040200	PAN HEAD BOLT	M4x10	1

KEY NO.	PARTS NO.	DESCRIPTION	SIZE	QTY
155	NH040700	NUT	M4	1
156	135029	RACK		1
157	135047	UPPER GUIDE TUBE		1
158	135006	HANDLE WHEEL		1
159	SR060400	HEX SOCKET BOLT	M6x20	1
160	135015	LOCATE BUSHING		1
161	135043	BUSHING		1
162	SJ080400	HEX SOCKET BOTTOM HEAD SCREW	M8x20	4
163	WS080000	SPRING WASHER	M8	9
164	135050	GUIDE BRACKET		1
165	135033	WORM CYLINDER		1
166	135062	FIXED PLATE		1
167	135049	GEAR		1
168	016320	FIXED BOLT		1
169	135046	COVER		1
170	SR089400	HEX SOCKET BOLT	M8x16	4
171	SN049200	COUNTER SUNK BOLT	M4x8	3
172	SS069400	SET BOLT	M6x16	1
173	AB198101	MITER GAUGE ASS'Y		1
	198101	GUIDE BAR		1
	198102	GUIDE		1
	198103	POINTER		1
	198104	NYLON WASHER		1
	198105	HANDLE	1/4"	1
	198106	MITER GAUGE BODY		1
	198107	SHAFT		1
	SN069200	COUNTER SUNK BOLT	M6x6	1
	SN059200	PAN HEAD BOLT W/FLANGE	M5x8	1
174	135079	BUSHING		1
175	SR060400	HEX SOCKET BOLT	M6x20	1
176	SF050200	PAN HEAD BOLT W/FLANGE	M5x10	2



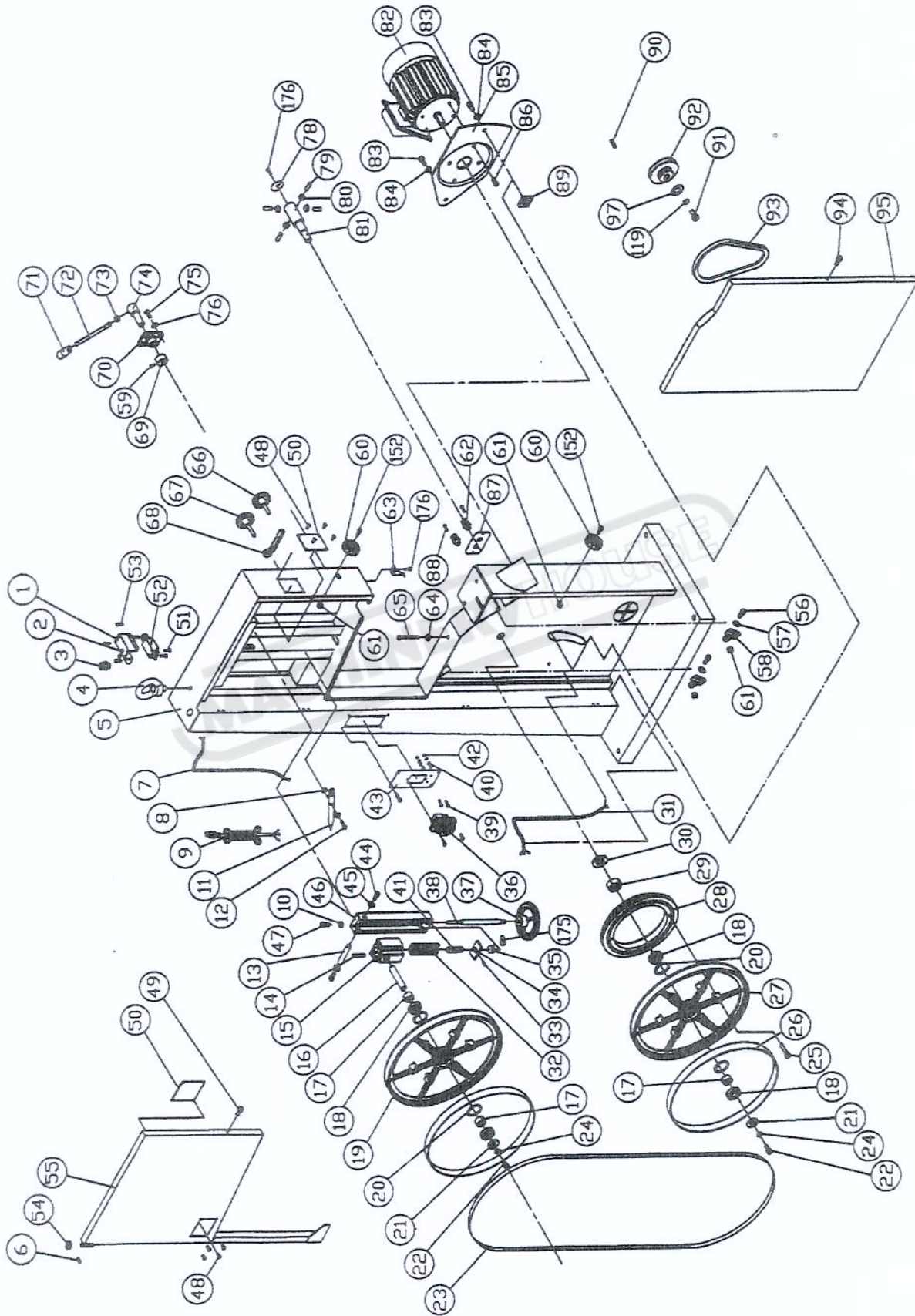

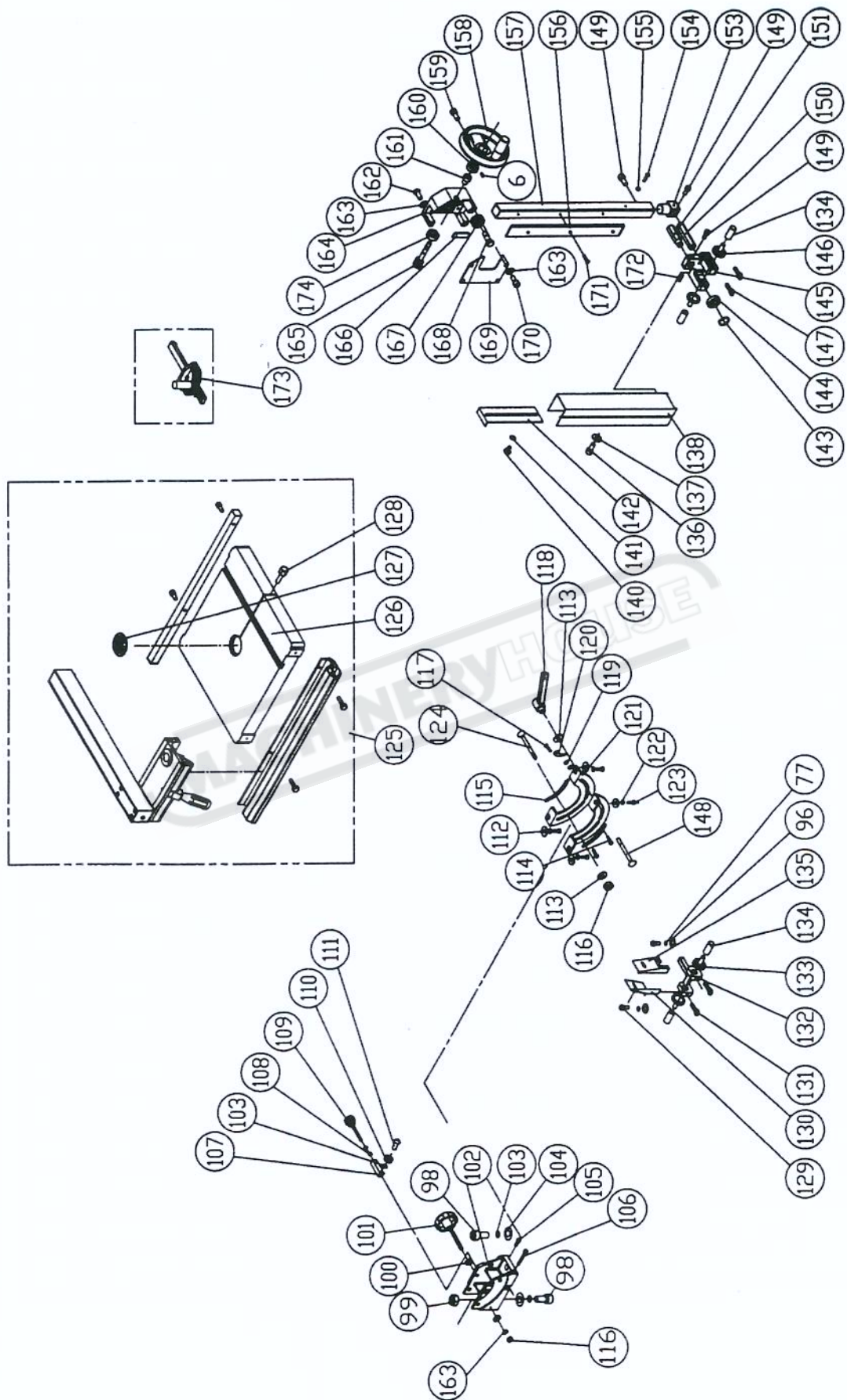

**Parts List For 19 Inch Band Saw  
Model No.. QF198003  
Rip Fence**

KEY NO.	PARTS NO.	DESCRIPTION	SIZE	Q'TY
1	198022	FIXED BASE	710	1
2	198002	ADJUST BASE		1
3	198003	FIXED SHGAFT		2
4	198005	SHAFT		1
5	198006	SPRING PIECE		1
6	198008	BRACKET	T=3	1
7	198024	SUPPORT TUBE	690	1
8	198010	INTERVAL SHEATH		4
9	198013	HANDLE		1
10	198012	ADJUST SCREW		1
11	198007	CONVEX		1
12	SR061103	HEX SOCKET BOLT	M6x55	4
13	198004	FIXED LUMP		1
14	198023	SQUARE TUBE	710	1
15	NH081300	NUT	M8	1
16	SF049100	PAN HEAD BOLT W/FLANGE	M4x6	2
17	198014	GUARD PIECE		2
18	198015	GUARD PIECE		2
19	198016	PLUGGED		2
20	ST039200	TAPPING SCREW	3.5x8	4
21	LM000539	SCALE		1
22	NH061000	NUT	M6	2
23	WS060000	SPRING WASHER	M6	2
24	SR069400	HEX SOCKET BOLT	M6x16	2
25	SH060400	HEX HEAD BOLT	M6x20	2
26	SF040200	PAN HEAD BOLT W/FLANGE	M4x10	1

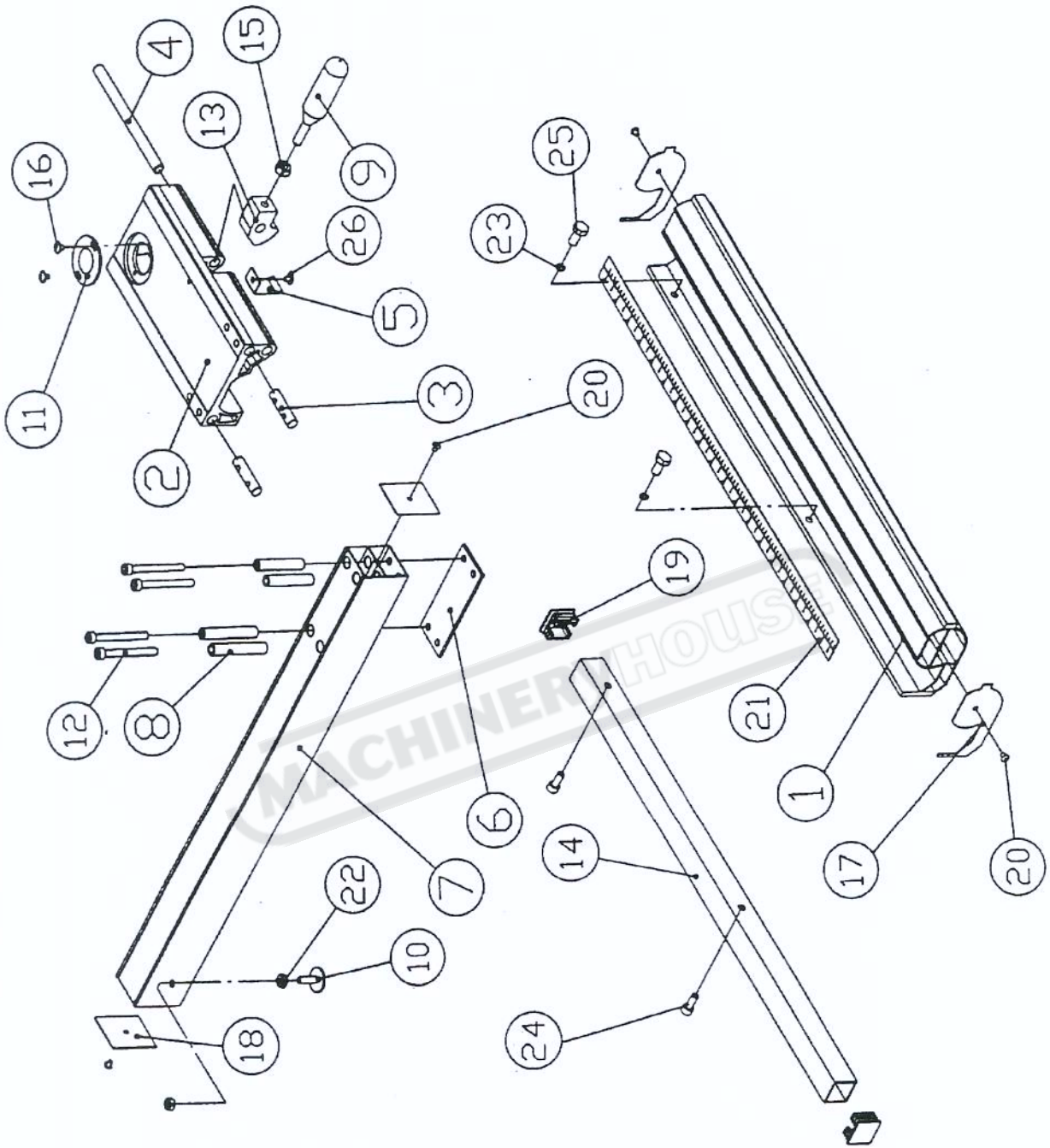

TOP GUIDE ASSEMBLY

AB135092

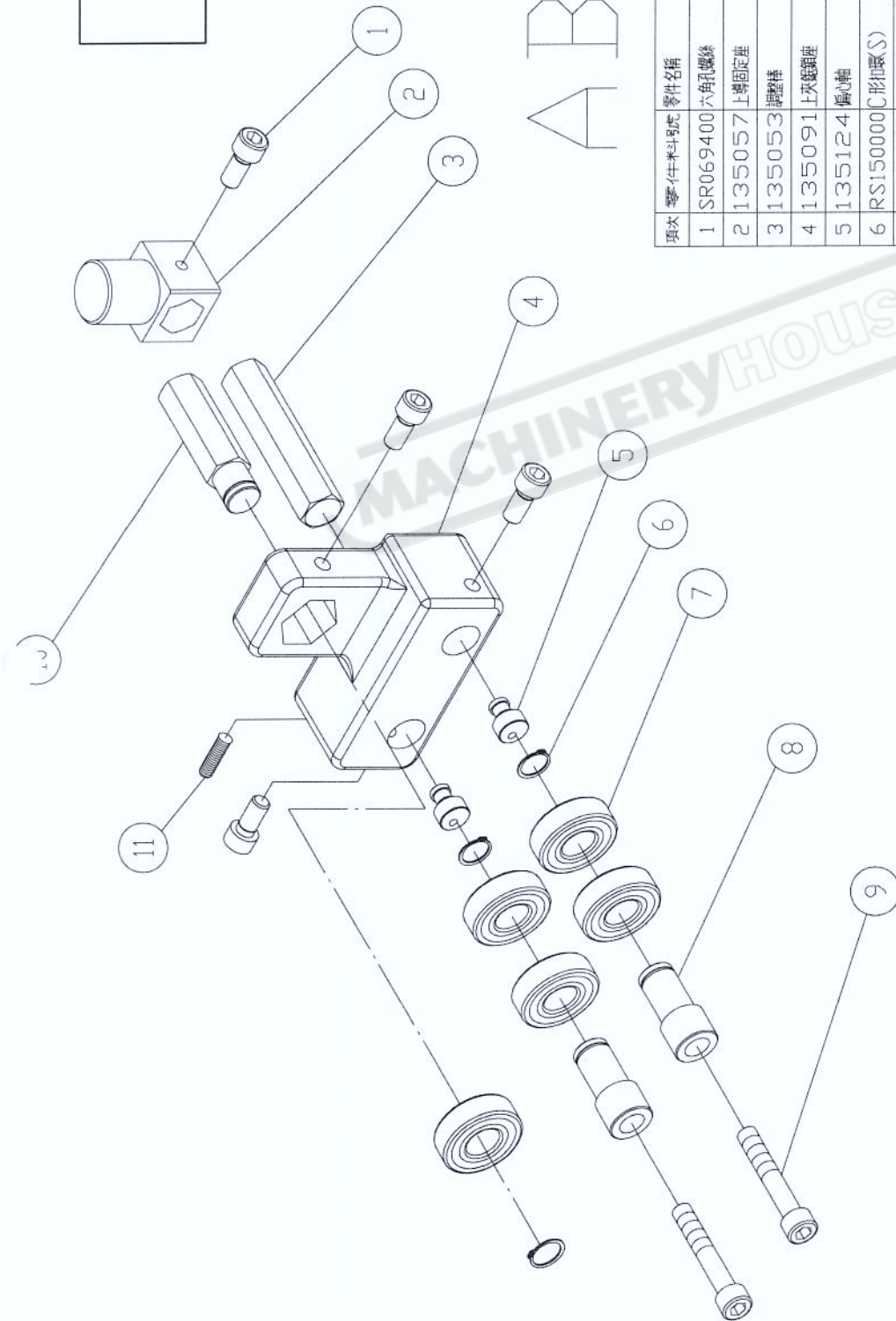

項次	零件號碼	零件名稱	PARTS NAME	規格	用量	備註
1	SR069400	六角孔螺絲	HEX SOCKET BOLT	M6x16	4	電黑
2	135057	上導固定座	UPPER GUIDE SUPPORT BLOCK		1	
3	135053	調整棒	ADJUST BAR		1	
4	135091	上夾鏈固定座	UPPER BLADE GUIDE SUPPORT		1	
5	135124	偏心軸	BIAS SHAFT		2	
6	RS150000	C形扣環(S)	ERTAINING RING	S15	3	
7	BB620202A	滾珠軸承	BALL BEARING	6202ZZ	5	
8	136445	手轉套	HANDLE BUSHING		2	
9	SR060700	六角孔螺絲	HEX SOCKET BOLT	M6x35	2	(特)電黑
10	135060	軸承套	UPPER SPACING SLEEVE		1	
11	SS060200	止付螺絲	SET BOLT	M6x10	1	電黑

W433 BP-430 W434 BP-480

NEW BEARING BLADE GUIDES FITTED FROM JULY 2006

**BOTTOM GUIDE ASSEMBLY**

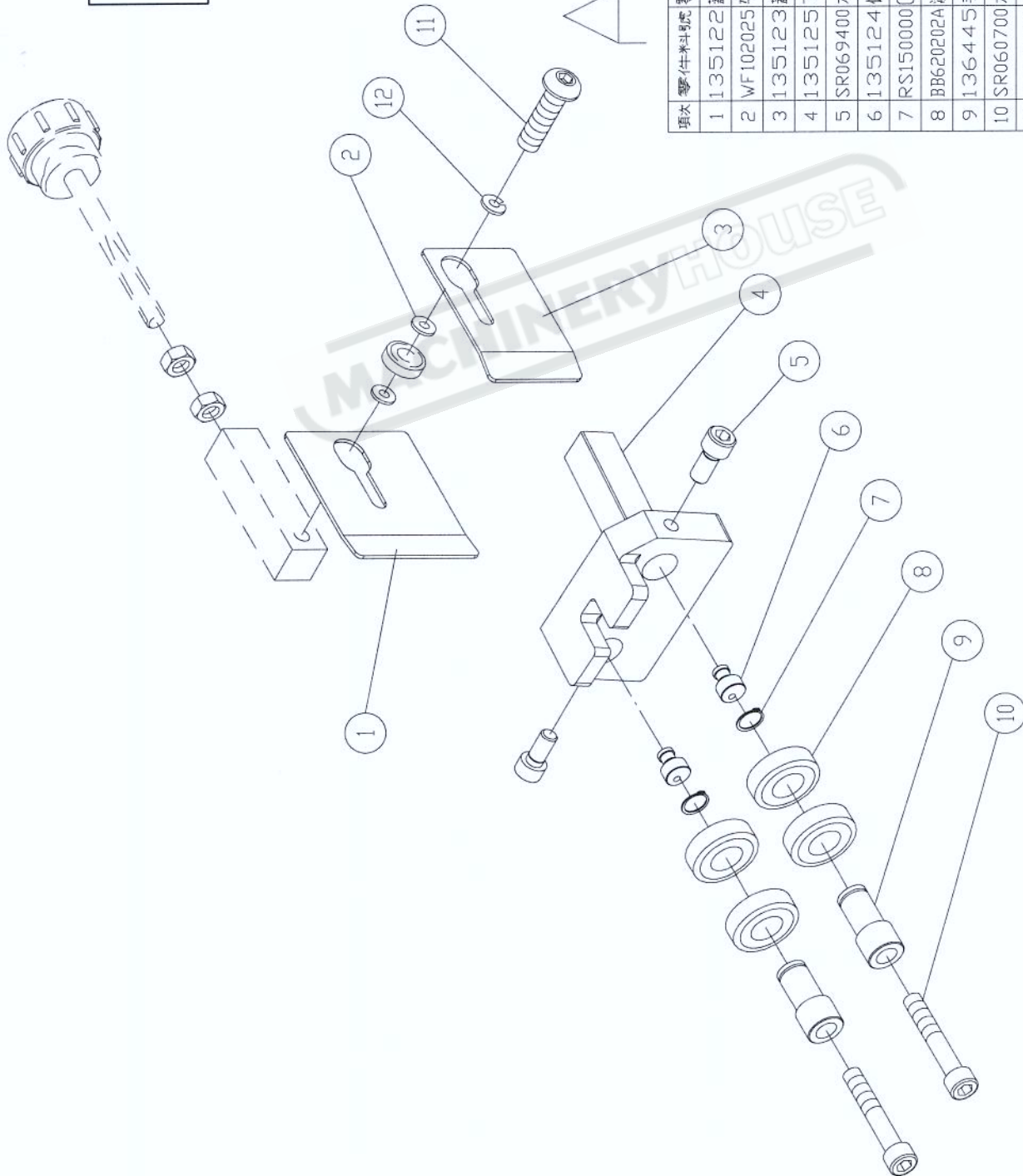

AB135095

項次	零件半導品號	零件名稱	PARTS NAME	規格	用量	備註
1	135122	蓋板(左)	LEFT COVER		1	
2	WF102025	平華司	WASHER	M10×Ø20	2	電氣(H)
3	135123	蓋板(右)	RIGHT COVER		1	
4	135125	下夾板鎖座	LOWER BLADE GUIDE SUPPORT		1	
5	SR069400	六角孔螺絲	HEX SOCKET BOLT	M6×16	2	電氣
6	135124	偏心軸	BIAS SHAFT		2	
7	RS150000	C形扣環(S)	ERTAINING RING	S15	2	電氣
8	BB620202A	滾珠軸承	BALL BEARING	6202ZZ	4	
9	136445	手轉套	HANDLE BUSHING		2	
10	SR060700	六角孔螺絲	HEX SOCKET BOLT	M6×35	2	(特)電氣
11	SJ100500	六角(○)螺絲	HEX SOCKET BOTTOM HEAD SCREW	M10×25	1	電氣(H)
12	WS100000	彈簧華司	SPRING WASHER	M10	1	電氣(H)

**W433 BP-430      W434 BP-480**

NEW BEARING BLADE GUIDES FITTED FROM JULY 2006